



MERLIN 55

Exceptional on-task endurance combined with outstanding sweeping performance – the Merlin 55 is favoured by many municipal and contracting operators.



FULL FEATURE SWEEPER
COMPACT CHASSIS

MERLIN 55

REDUCED FUEL
CONSUMPTION

REDUCED
MAINTENANCE

DECREASED
NOISE AND
ENGINE
POLLUTION

A full-feature 5.5 cubic metre sweeper on a 7.5-tonne chassis.

Favoured by many municipal and contracting operators, the Merlin 55 is the most effective road sweeper available in the 7.5 tonne GVW range.

The Merlin 55 boasts a payload performance that is a premium in its class. Scarab's industry-leading single-engine system delivers a significant advantage over any auxiliary-engine powered sweeper on the same chassis.

Furthermore, thanks to the innovative design, this system affords the Merlin 55 to use a range of powerful sweeping options, such as dual-sweep and high-pressure water, and a 900-litre water tank – without compromising the weight or performance of the machine.



FULL FEATURE SWEEPER COMPACT CHASSIS



**GREATER
PAYLOAD**

**LESS
WEIGHT**



**Unrivalled sweeping performance
in its class:**

SIZE:	7.5 - 8.3 tonne GVW
SWEEPING SPEED:	0 - 20mph/0 - 32kph
HOPPER CAPACITY:	5.5 cubic metres
WATER TANK:	900 litres
ENGINE:	Single Engine Hydrostatic
TYPICAL PAYLOAD:	1750 - 2000kg
SWEEP WIDTH:	2290mm single/2850mm dual

Standard specification

- Stainless steel hopper
- Scarab CANbus control panel incorporating operational information, data logging and self diagnosis
- 900 litre corrosion resistant water tank



Inside the Merlin 55's hopper

STRONG, ROBUST HOPPER

The hopper is completely manufactured from strong, corrosion and abrasion-resistant 4003 stainless steel, which is shot blasted before a two-pack epoxy primer and a hard-wearing topcoat is applied.

Particulate screening, via a hinged stainless steel mesh filter, swings down for ease of cleaning and provides access to the stainless steel inlet cone.





- 
- Trailed widesweep brush is adjustment-free and designed to ensure parallel usage.
 - Trailed, robust, steel suction nozzle for durability.
 - Adjustable dust-suppression jets.
 - Short suction hoses are an easy and low-cost replacement, and are simple to clean.
 - Trailed channel brush mechanism with adjustable brush-pressure control option.
 - Simultaneous 'dual sweep' and 'high pressure street' wash option.



EXTENSIVE SWEEPING CAPABILITIES

The Merlin 55 is available in both single and optional dual sweep configuration. When the suction nozzle, side brush and widesweep functions are in operation the Merlin 55 can sweep at a 2290mm width. However, the brushes can reach an impressive 2850mm span when simultaneously dual sweeping.

With variable brush speeds, optional down pressure and swivelling widesweep, the Merlin 55 is proficient in any sweeping application.

POWERFUL & RELIABLE SUCTION PERFORMANCE

A stainless steel centrifugal roof mounted impeller is positioned to produce an efficient airflow path for high suction performance and reduced power consumption. The fan chamber is easily accessed for cleaning.

Particulate screening, via a hinged stainless steel mesh filter, is pleated to give maximum surface area and reduce blocking – it also swings down for ease of cleaning.

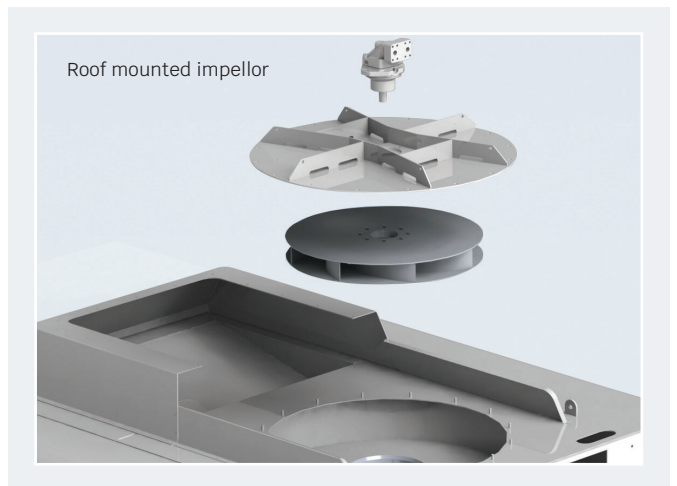

POWER & CONTROL

SINGLE ENGINE, SINGLE EMISSION, NO COMPROMISE

Scarab is the pioneer of the environmentally friendly single-engine truck-mounted sweeper and continues to lead the market in this field. As a result of the single engine system, the Merlin 55 benefits from reduced fuel consumption, decreased noise and engine pollution, less weight, greater payload and reduced maintenance.



CANBUS CONTROL SYSTEM

Scarab's CANbus control system revolutionised the way sweepers are operated and maintained. It continues to evolve today to offer market leading sweeper control.

Our latest CANbus control system offers colour coded door-pod and pedestal controls with key sweeping functions visible at a glance, and comfortably within reach. The large graphical display clearly indicates sweeping configuration and provides the user with regular updates on the vehicle, including warnings and service reminders. What's more, with real-time data-logging built into the system, you can monitor your performance and keep your sweeper functioning at its very best. Scarab's CANbus includes universal connectors for fitment of Global Positioning System (GPS) and the option of real-time data availability via telematics.

“Scarab are at the cutting edge of developing innovative solutions to be more efficient with dust collection, reducing noise pollution and lowering carbon footprints”.



Hydrostatic System

The Scarab designed hydrostatic gearbox is installed in the chassis driveline and allows the sweeping components to be powered directly from the chassis engine. As well bringing a range of benefits such as reduced weight, increased payload, reduced fuel consumption and lower emissions, it also offers a range of operator benefits with its simple joystick control for forward and reverse, allowing single-pedal control which reduces fatigue and enables the driver to fully concentrate on sweeping.

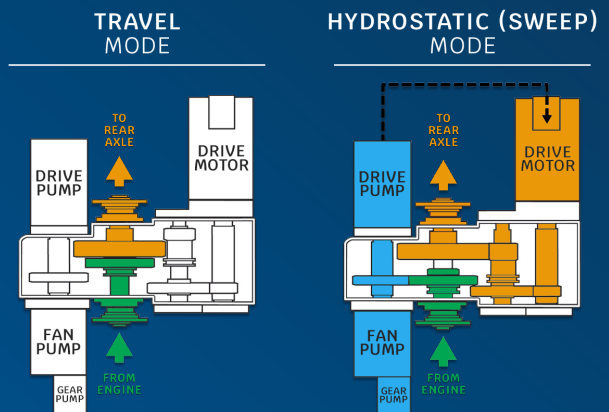

AFTER SALES SUPPORT

Our dedicated After Sales team are Scarab Sweepers' front-line ambassadors and it's their aim to provide you with the highest level of support for the lifetime of your vehicle, delivered through:

- **Industry renowned after sales care.**
- **A range of extended warranty options.**
- **A choice of 'Service', or 'Repair and Maintenance' solutions to suit your needs.**

STANDARD FEATURES

SWEEPING WIDTHS (based on a typical 7.5 tonne GVW chassis)

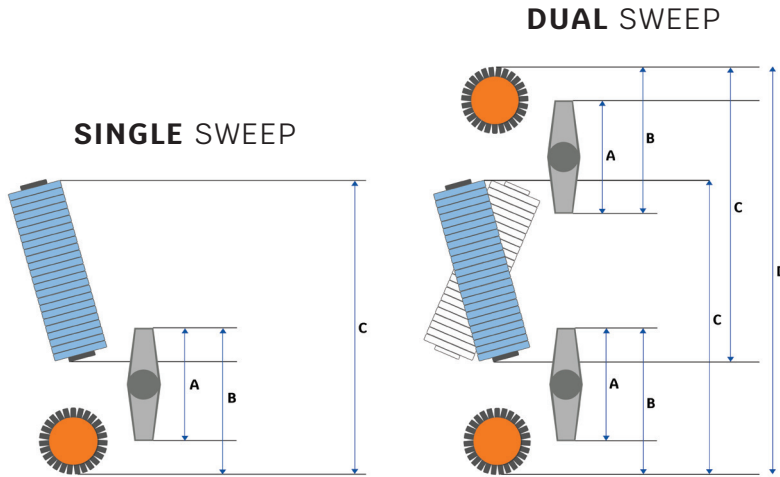

A Suction nozzle only	740mm
B Nozzle & side brush	1135mm
C Nozzle, side brush & widesweep	2290mm
D Simultaneous dual sweep	2850mm

Slight variations to the foregoing dimensions can occur according to individual chassis specifications.

WEIGHTS AND DIMENSIONS

PAYLOAD

Typical Payload Potential 1750–2000kg

TYPICAL DIMENSIONAL DATA

Length overall	5700mm
Wheelbase	3150mm
Width overall	2180mm
Overall height	
hopper lowered	2970mm
hopper raised	4090mm

CAPACITIES

Hopper*	Gross volume 5.5m ³ Net/Payload volume 4.7m ³
Water tank**	900 litres

* Calculated in accordance with European Standard EN15429

** Subject to chassis selected

MADE IN BRITAIN, TRUSTED WORLDWIDE



UPGRADES/ENHANCEMENTS

OPTIONS (other options and operator specific requirements are available upon request)



*Some options listed are chassis dependent

WATER

- High-pressure/high-volume pump with hand lance and self-retracting hose reel.
- Additional dust suppression for suction nozzles (a 4-jet water-boost bar in front of the nozzle).
- Additional dust suppression for suction tubes (four additional jets at the top of the suction tube).
- Detergent injection kit for use with the hand lance on difficult cleaning operations.
- Hydrant standpipe, key and 3 metres

of 50mm lay-flat hose for on-task replenishment of water.

- Simultaneous wash and sweep facility.

BRUSHES

- Dual sweep (a second channel brush on opposite side of the sweeper + swivelling widesweep).
- Simultaneous dual sweep (both channel brushes and widesweep operate together).

SUCTION SYSTEM

- Door-mounted wander hose.

MISCELLANEOUS

- Reduction gearbox in driveline for Unidrive variants.
- CCTV camera to offside brush and/or rear of vehicle.
- Centralised lubrication system (either manual or automatic).
- Alternative or additional beacons.
- Fire extinguisher.



The Merlin 55 is just one of Scarab's expertly engineered truck-mounted road sweeping solutions. Because of its flexibility, the Merlin 55 can be fitted to a wide variety of chassis from as low as 7.5 tonne GVW. For details on suitable chassis specifications, please contact your local distributor.

MERLIN 55

www.scarab-sweepers.com

Dealership

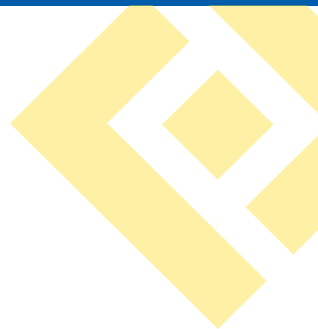

SCARAB SWEEPERS LTD

Pattenden Lane, Marden,
Tonbridge, Kent,
United Kingdom TN12 9QD

TEL +44 (0)1622 831006
www.scarab-sweepers.com